

# 620 RAPID

# FAAC

for beams up to 4 m



■ Beam



■ Self-supporting barrier body



## ■ Use versatility

The "rapid" version of the FAAC 620 offers the continuity solution to the traffic problem. It enables uninterrupted use frequency thanks to real-time detection of oil temperature. For barriers of up to 3 metres in length, opening time is under 2 seconds.

## ■ Totally flexible

The FAAC 620 range is equipped with electronic deceleration at opening and closing. A version with articulated barrier for low ceilings is available on request.

## ■ Long term reliability

Use of cutting-edge materials and treatments such as cataphoresis and niplay, plus tried-and-tested FAAC hydraulic technology, all combine to ensure long-life.

## ■ Leading-edge technology

SMT microprocessor electronic technology is supplied standard to ensure exceptional performance. By means of an optional card, the barrier can also control auxiliary services and an additional opposing beam. Barrier statuses can be signalled to traffic control devices.

## ■ Electronic intelligence

The electronic intelligence of the 620 range functions by means of three differentiated logics: automatic, semi-automatic and parking (P) - the latter was expressly designed for automatic parking systems.

## SPECIFICATIONS

Automatic barrier for beams up to 4 m • Use frequency 100% • Opening/closing time < 3 s • Activation system comprising hydraulic pump unit, plunger pistons, equaliser and transmission shaft • Balancing by compression spring • Internal stops adjustable for open or closed beam positions • Load bearing housing in steel protected by cataphoresis treatment and polyester powder paint RAL 2004 • Overall dimensions 200x380x1080 mm (LxWxH) • Protection class IP 44 • Release device accessible from the outside by triangular or customised key (optional) • Hydraulic pump unit with hydraulic locking at opening and closing • Electric motor power supply 230 Vac (+6% -10%) - 50(60) Hz • Electric motor power 220 W • Thermal protection at 120°C built into motor winding • Operating ambient temperature -20°C ÷ +55°C • Single-phase motor with two rotation directions (1,400 rpm) • Hydraulic gerotor pump (max low noise) • Pump flow rate 1.5 - 2 l/m • Die-cast distribution flange • Separate control of opening and closing force by by-pass valves • Tank in anodised aluminium • Mineral hydraulic oil with additives • Travel-limit deceleration • Adjustable deceleration angle by cams • Automatically activated cooling ventilation • Designed to accommodate rectangular, articulated rectangular, round, pivoting round beams • Built-in electronic control equipment

# 620 RAPID

## INSTALLATION LAYOUT

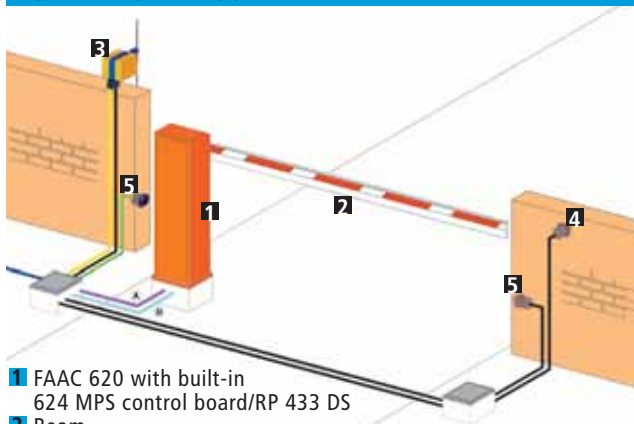

- 1 FAAC 620 with built-in 624 MPS control board/RP 433 DS
- 2 Beam
- 3 FAACLIGHT
- 4 FAAC T10
- 5 FAAC FOTOSWITCH

Low voltage cabling		Tubazioni potenza (230V)	
(A)	<ul style="list-style-type: none"> <li>3 cables 3x0,5</li> <li>1 cable 2x0,5</li> </ul>	(B)	<ul style="list-style-type: none"> <li>1 cable 2x1,5+T</li> <li>1 cable 2x1,5</li> </ul>
N.B: Cable diameters in mm <sup>2</sup>			

- 1 Balancing spring
- 2 Hydraulic pump unit
- 3 Cylinders with plunger pistons
- 4 Release device by triangular key
- 5 624 MPS control board

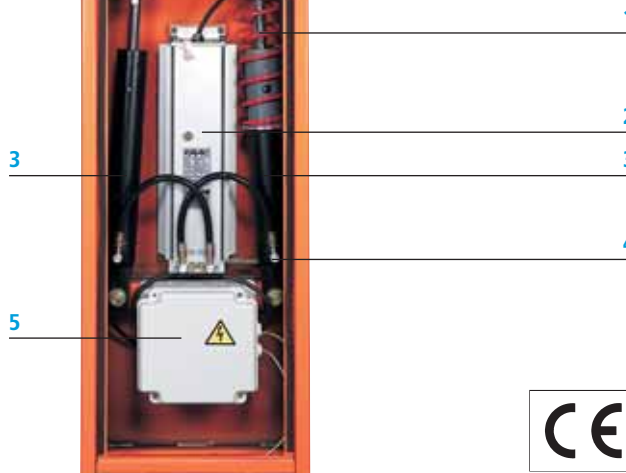

Technical characteristics	620 RAPID LH/RH
Power supply	230 Vac (+6% -10%) 50 (60) Hz
Electric motor	Single-phase, bi-directional
Absorbed power	220 W
Absorbed current	1A
Motor rotation speed	1.400 - 2.800 rpm
Pump flow rate	1,5 /2 l/min.
Thermal protection on motor winding	120°C
Effective torque	0÷100 / 0÷80 Nm
Electronic deceleration	Adjustable with cams
Operating ambient temperature	-20°C ÷ +55°C
Weight	73 kg
Type of oil	FAAC HP OIL
Barrier body treatment	Cataphoresis
Paint	RAL 2004 polyester
Protection class	IP 44
Cooling	Forced air
Type of beam	rectangular: standard - with skirt - articulated standard rectangular - round: standard - pivoting

Technical characteristics of 624 MPS control board	
Power supply	230 Vac (+6% -10%) 50 (60) Hz
Motor maximum load	300 W
Accessories output	24 Vdc 500 mA max
Operating ambient temperature	-20°C ÷ + 55°C
Three protection fuses	0,25 A transformer - 5 A motor - 1,6 A accessories
Enclosure dimensions	174x178x102 mm (LxHxD)
Protection class	IP 55

**SMT technology**  
**Programmable functions:** - Three function logics - A/E/P, Pause times, Pre-flashing, Electronic deceleration (short or long), Operation of indicator-light  
**Inputs signalling LED, alarm and limit-switch**  
**Terminal board outputs** - Indicator-light, flashing Lamp  
**Terminal board inputs** - Open, stop, safety devices, anti-panic  
**Rapid connectors for:** Motor, limit-switch, decoding cards/card receivers, optional cards  
**Reset push-button**

Model	Use			Control board
	Beam max. length (m)	Opening time (s)	Use frequency (%)	
620 RAPID LH/RH	4,00	2 (3m) 3 (4m)	Continuous duty	624 MPS built-in
620 RAPID ART. LH/RH	3,00 (articulated)	3	Continuous duty	624 MPS built-in

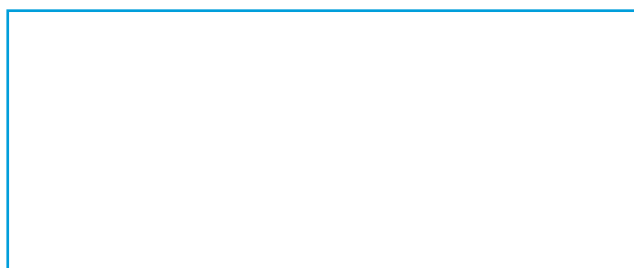

## DIMENSIONS

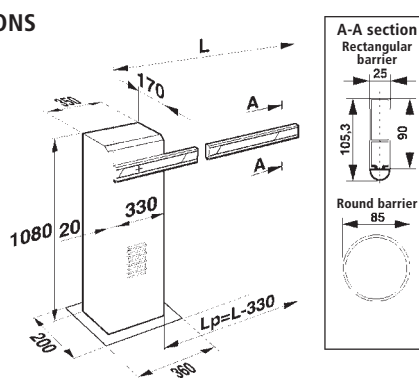

L = Beam length  
 Lp = Transit space length

Values in mm



FAAC S.p.A. via Benini, 1  
 40069 Zola Predosa - Bologna (Italy)  
 Tel. +39 051 61724 · Fax +39 051 758518  
 www.faacgroup.com

